

W. R. HODGE
Lathe for Turning Wood.

No. 162,819.

Patented May 4, 1875.

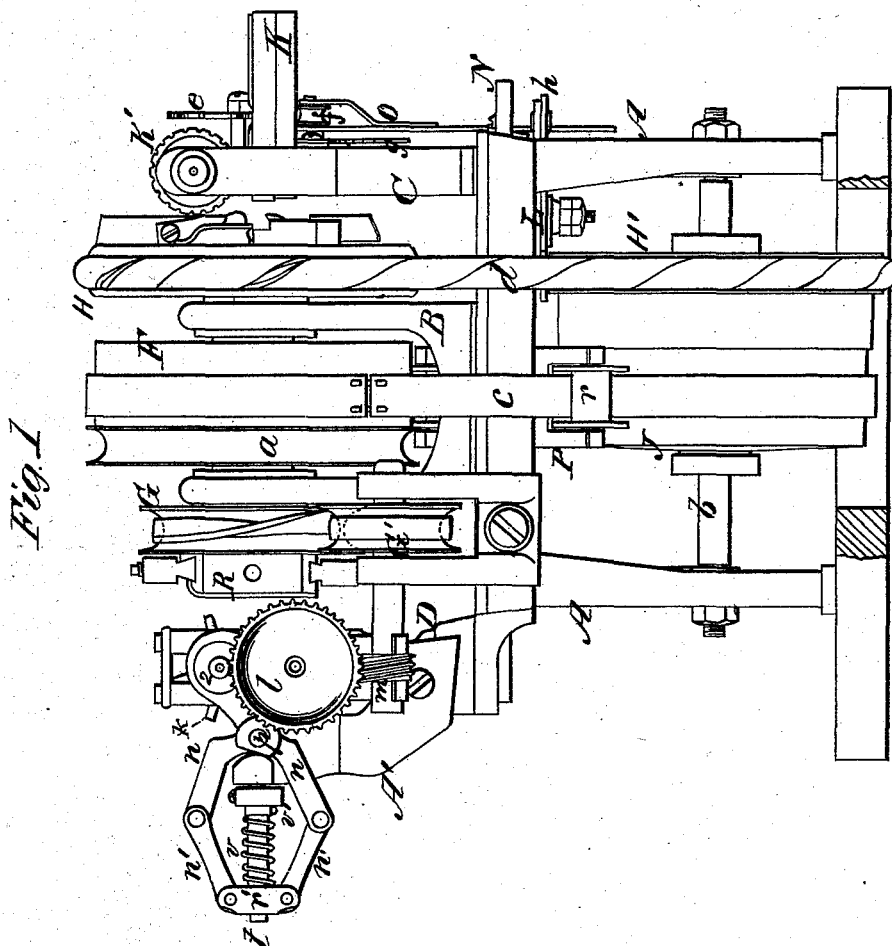

WITNESSES
Robert Everett
E. H. Bates

INVENTOR
William R. Hodge
Chipman & Co.

Attorneys

W. R. HODGE
Lathe for Turning Wood.

No. 162,819.

Patented May 4, 1875.

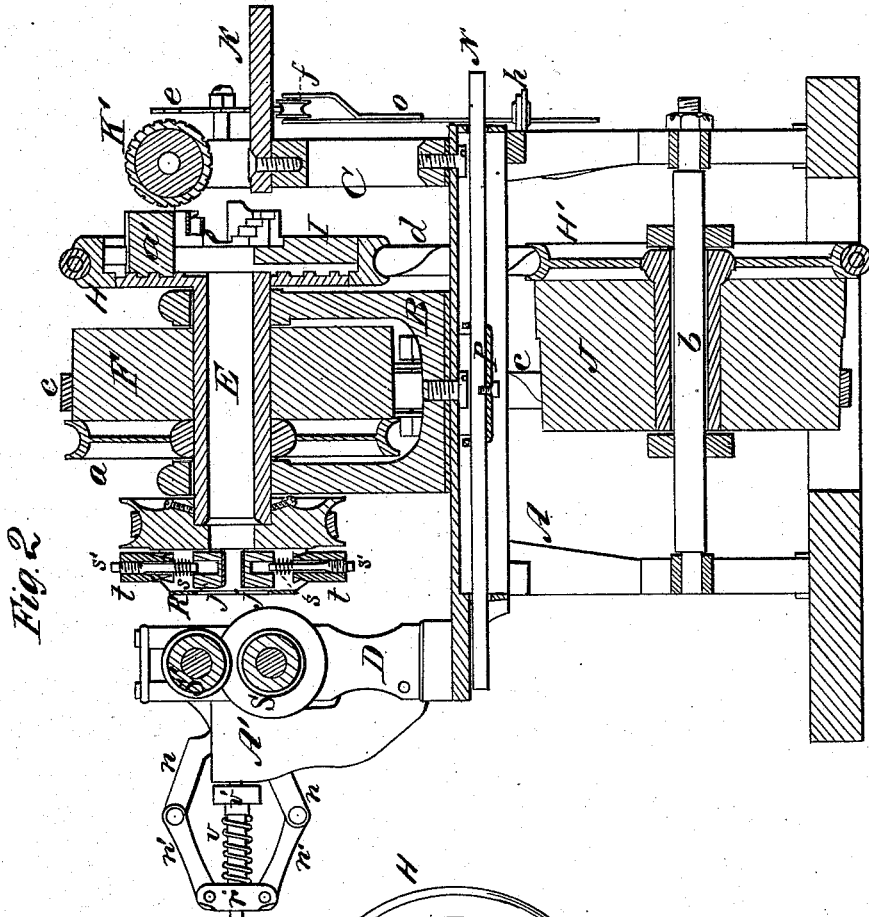

Fig. 2

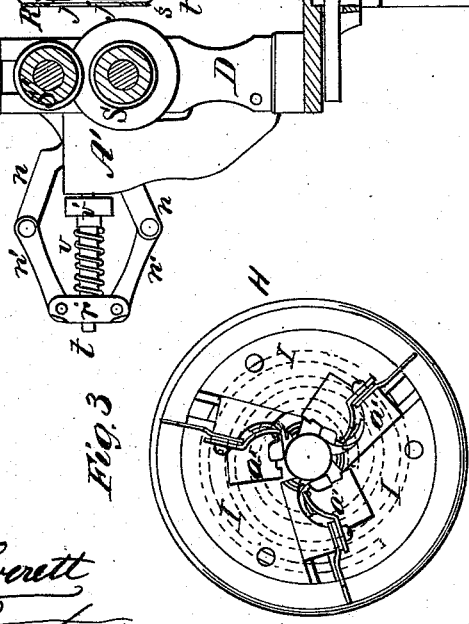

Fig. 3

WITNESSES
Robert Everett
E. H. Bates

INVENTOR
William R. Hodge
Chipman & Smith & Co

Attorneys

W. R. HODGE
Lathe for Turning Wood.

No. 162,819.

Patented May 4, 1875.

Fig. 4

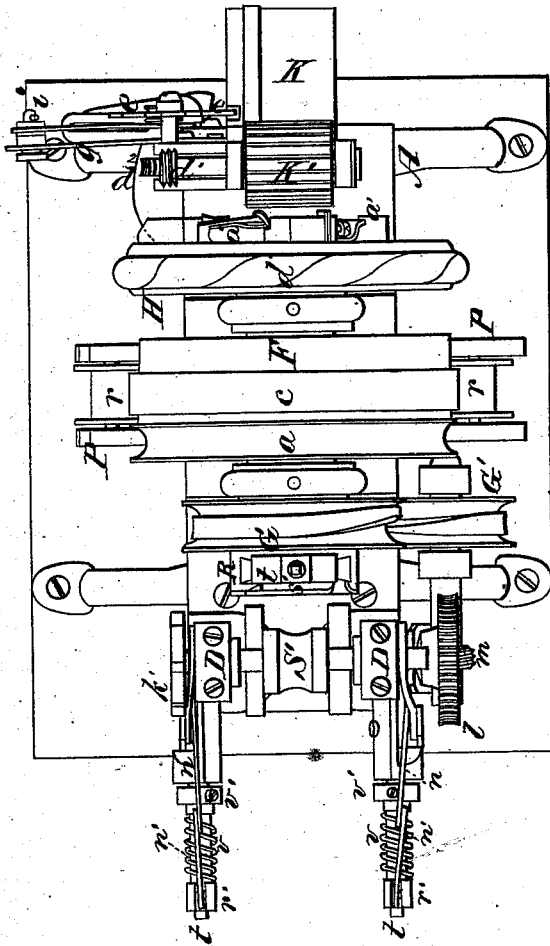

WITNESSES

Robert Everett
E. H. Bates

INVENTOR

William R. Hodge
Chipman & Hunsman & Co

Attorneys

W. R. HODGE
Lathe for Turning Wood.

No. 162,819.

Patented May 4, 1875.

Fig. 5.

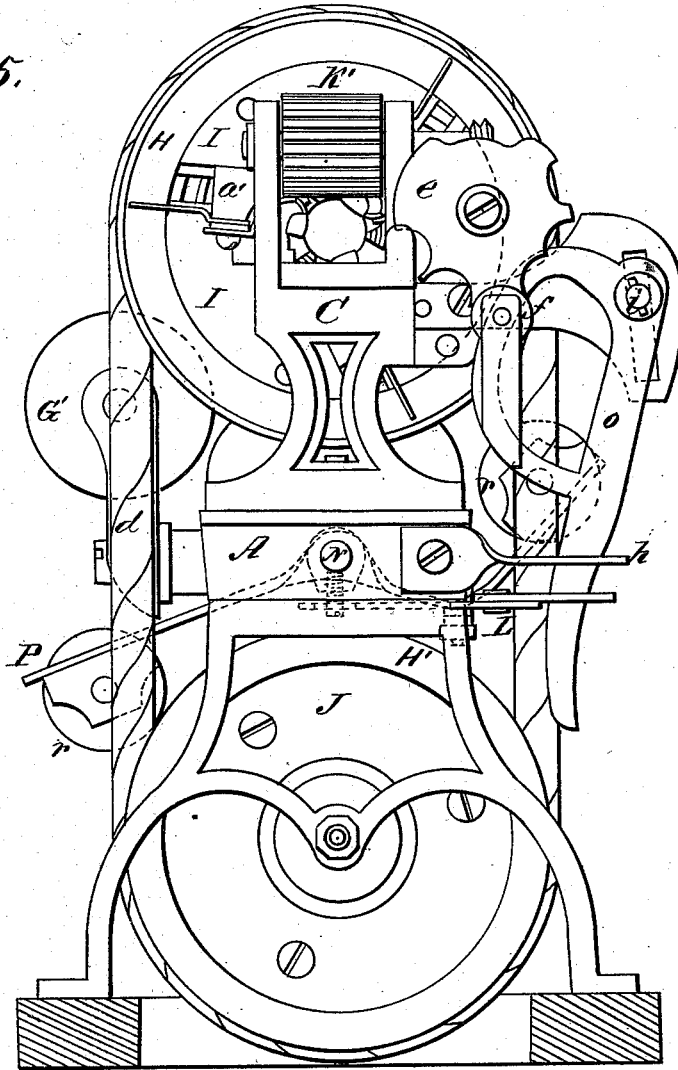

WITNESSES

Robert Everett
E. A. Bates

INVENTOR

William R. Hodge,
Chipman & Sumner & Co.,

ATTORNEYS

UNITED STATES PATENT OFFICE.

WILLIAM R. HODGE, OF EAST NEWARK, NEW JERSEY.

IMPROVEMENT IN LATHES FOR TURNING WOOD.

Specification forming part of Letters Patent No. **162,819**, dated May 4, 1875; application filed September 19, 1874.

To all whom it may concern :

Be it known that I, WILLIAM R. HODGE, of East Newark, in the county of Hudson and State of New Jersey, have invented a new and valuable Improvement in Lathe for Turning Wood; and I do hereby declare that the following is a full, clear, and exact description of the construction and operation of the same, reference being had to the annexed drawings, making a part of this specification, and to the letters and figures of reference marked thereon.

Figure 1 of the drawing is a representation of a front view of my turning-machine. Fig. 2 is a vertical sectional view, Fig. 3 is a detail view, Fig. 4 is a top view, and Fig. 5 is a plan view, of the same.

This invention relates to machines for turning irregular forms; and it consists in a certain novel combination of cone-pulleys and radially-adjustable cutters with a belt-shifter, a pattern-plate, and a pressure-roller, hereinafter explained, whereby the cutters are automatically adjusted by said pattern-plate, and any desired form given to the stuff passed through the machine. It also consists in novel mechanism for smoothing the turned stuff and drawing the same through the machine, as will be hereinafter explained.

In the annexed drawings, A designates the frame or table of the machine, and B C D are standards, which are secured on top of the frame A. E designates a hollow spindle, through which the stuff passes after it leaves the cutters; and F is a cone-pulley, which, with a grooved pulley, *a*, is keyed fast on the spindle E. G is a small pulley, for communicating motion to grooved drawing-rollers, hereinafter explained. H is a grooved pulley, which is hollow, and free to be turned around the spindle E; and I I I are three segments, which are secured on one end of the spindle E, with spaces between them for receiving cutter-carrying blocks *a'*, and allowing these blocks to be adjusted radially. The blocks *a'* have teeth on them, which are received into a convolute groove formed in the face-plate of pulley H, as shown in Fig. 3. By turning pulley H on the spindle E, the cutters can be caused to approach or recede from the axis of the spindle. J designates a cone-pulley, which,

with a grooved pulley, H', is free to turn on a fixed horizontal rod, *b*, and which receives rotation from the cone-pulley F by means of a belt, *c*. A belt, *d*, is passed around the pulleys H H', for the purpose of transmitting motion to the pulley H, for adjusting the cutters.

It will be observed that the cone-pulleys F J are tapered in opposite directions, so that by shifting the belt *c* on them varying speed can be given to the pulley J and pulley H.

K designates a table, on which the work lies while being fed to the cutters; and K' is a grooved pressure-roller, having its bearings in the standard U. This roller K is turned by the work passing under it, and on one end of its shaft is a worm-wheel, *d'*, which gives slow rotation to a wheel, *d''*, on the shaft of which is a pattern-plate, *e*. The edge of plate *e* is scalloped to form the pattern, and against this edge a grooved roller, *f*, is held. Roller *f* is applied to a lever, *o*, which has its fulcrum at *i* in a slotted plate, *g*, and this fulcrum can be adjusted vertically. The lower part of the lever *o* passes through a fixed slotted guide, *h*, and also through one end of a horizontal crooked lever, L, which has its fulcrum beneath the top of frame A. Lever L is loosely attached to a horizontal rod, N, which is free to move endwise in the ends of the frame A, and which is arranged beneath the top of this frame. To this rod N a carriage, P, is secured, one end of which is turned up, and the other end is turned down. Both ends of the carriage have flanged rollers *rr* applied to them, which serve as tension-rollers, for acting on the belt *c*, and keeping it sufficiently tight to give a positive movement to the cone-pulley J. The flanged rollers *rr* also serve, in combination with the pattern-plate *e* and the lever-connections with the carriage P, as means for shifting the belt *c* on its pulleys F J. The cone-pulley F, its spindle E, and the cutter-segments I all receive a given uniform rotation; but the pulley H receives a differential motion, by reason of the pattern-plate *e* shifting the belt *c* on its pulleys F J.

After the stuff is turned it is smoothed by means of sand-paper on the concave surfaces of two blocks, *jj*, which are applied in a head, R, on pulley G, and acted on by means of springs *s* and set-screws *s'*, which latter are

tapped through removable blocks *t t*, dovetailed into the head *R*. The smoothing-blocks are by these means adjustable, and capable of yielding and accommodating themselves to the inequalities of the surface to be smoothed. *S S'* are grooved rollers, for drawing the stuff through the machine. The shafts of these rollers have their bearings in the standards *D*. The lower roller *S* is flanged, and on its shaft spur-wheels *k l* are keyed. The wheel *l* engages with a worm, *m*, which is on the shaft of a pulley, *G'*, which receives rotation from the pulley *G* by means of a crossed belt. (Shown in Fig. 1.) The wheel *k* has very long teeth, which engage with corresponding teeth of a wheel, *k'*, on the shaft of the upper roller *S'*. The shafts of the rollers *S S'* have circular collars *2* on them, which are embraced by the ends of shear-levers *n n*, having their fulcrums *p* on brackets *A'*. The rear ends of the levers *n n* are connected to slides *r' r'* by means of links *n' n'*, and the slides are free to move longitudinally on fixed horizontal rods *t t*. *v v* designate helical springs, and *v' v'* collars, which are on the rods *t t*. The collars *v'* are adjustable, for increasing or diminishing the force of the springs. These springs, it will be seen, operate, through the medium of the links and shear-levers, to keep the drawing-rollers forcibly pressed against the stuff during the turning and smoothing operations, which press-

ure can be increased or diminished by adjusting the collars *v' v'*.

What I claim as new, and desire to secure by Letters Patent, is—

1. In combination with the radially-adjustable cutter-carrying blocks *a'*, the loose pulley *H*, and the hollow spindle *E*, the cone-pulleys *F J*, pulley *H'*, belt *d*, belt *c*, shifting carriage *P*, lever-connections *L o*, pattern-plate *e*, and driving-roller *K'*, substantially as described.

2. Sequents *I* and cutter-carrying block *a'* on hollow spindle *E*, in combination with the pulley *H*, turning loosely on spindle *E*, substantially as and for the purpose described.

3. The cone-pulley *F*, fast on the hollow spindle *E*, and the cone-pulley *J*, loose on shaft *b*, in combination with carriage *P*, belts *c*, lever-connections *L o*, and pattern-plate *e*, actuated as described.

4. In a machine for turning irregular forms, the combination of a pattern-plate, *e*, a belt-shifter, and cone-pulleys *F J*, substantially as described.

In testimony that I claim the above I have hereunto subscribed my name in the presence of two witnesses.

WILLIAM RAMSAY HODGE.

Witnesses:

THOS. P. O'REILLY,
JOHN D. HODGE.